

NSE4_FGT-5.6^{Q&As}

Fortinet NSE 4 - FortiOS 5.6

Pass Fortinet NSE4_FGT-5.6 Exam with 100% Guarantee

Free Download Real Questions & Answers **PDF** and **VCE** file from:

https://www.certbus.com/nse4_fgt-5-6.html

100% Passing Guarantee
100% Money Back Assurance

Following Questions and Answers are all new published by Fortinet
Official Exam Center

- ⚙️ **Instant Download** After Purchase
- ⚙️ **100% Money Back** Guarantee
- ⚙️ **365 Days** Free Update
- ⚙️ **800,000+** Satisfied Customers



QUESTION 1

What is the purpose of the Policy Lookup feature? Response:

- A. It searches the matching policy based on input criteria.
- B. It creates packet flow over FortiGate by sending real-time traffic.
- C. It finds duplicate objects in firewall policies.
- D. It creates a new firewall policy based on input criteria.

Correct Answer: A

QUESTION 2

Examine the exhibit, which shows a FortiGate device with two VDOMs: VDOM1 and VDOM2. Both VDOMs are operating in NAT/route mode. The subnet 10.0.1.0/24 is connected to VDOM1.

The subnet 10.0.2.0/24 is connected to VDOM2. There is an inter-VDOM link between VDOM1 and VDOM2.

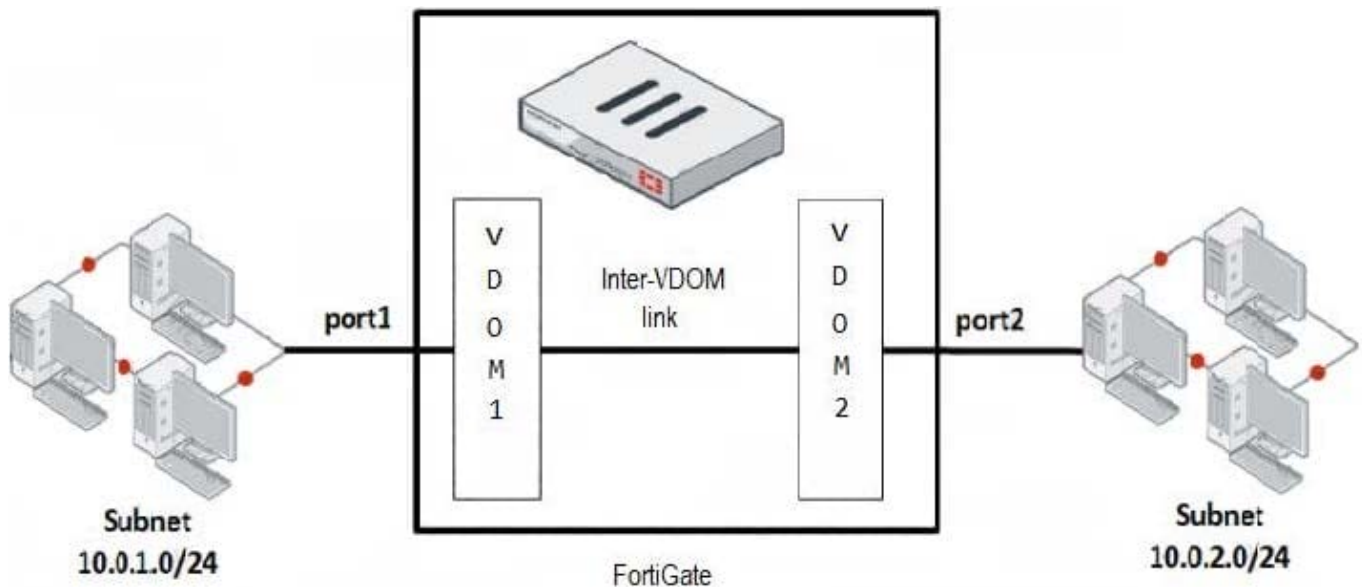

What is required in the FortiGate configuration to route traffic between both subnets through an inter-VDOM link?

Response:

- A. A firewall policy in VDOM1 to allow the traffic from 10.0.1.0/24 to 10.0.2.0/24 with port1 as the source interface and port2 as the destination interface.
- B. A static route in VDOM1 for the destination subnet of 10.0.1.0/24.
- C. A static route in VDOM2 with the destination subnet matching the subnet assigned to the inter-VDOM link.
- D. A static route in VDOM2 for the destination subnet 10.0.1.0/24.

Correct Answer: D

QUESTION 3

An administrator has configured central DNAT and Virtual IPs. Which of the following can be selected in the firewall policy Destination Address field?

(Choose two.)

Response:

- A. VIP object
- B. Mapped IP address object of the VIP
- C. Address object all
- D. IP pool

Correct Answer: BC

QUESTION 4

An administrator is configuring an IPsec VPN between site A and B.

The Remote Gateway setting in both sites has been configured as Static IP Address. For site A, the local quick mode selector is 10.0.1.0/24 and the remote quick mode selector is 10.0.2.0/24.

How must the administrator configure the local quick mode selector in site B?

Response:

- A. 10.0.2.0/24
- B. 0 0.0.0.0/0 0
- C. 10.0.1.0/24
- D. 0 10.0.0.0/8

Correct Answer: A

QUESTION 5

Which statements are true regarding incoming and outgoing interfaces in firewall policies?

(Choose two.)

Response:

- A. An incoming interface is mandatory in a firewall policy, but an outgoing interface is optional.
- B. A zone can be chosen as the outgoing interface.
- C. Only the any interface can be chosen as an incoming interface.
- D. Multiple interfaces can be selected as incoming and outgoing interfaces.

Correct Answer: BD

QUESTION 6

What statement is true regarding web profile overrides? Response:

- A. It is not possible to completely override a web filter profile.
- B. Configured users can activate this setting through an override link on the FortiGuard block page.
- C. This feature is available only in flow-based inspection.
- D. It is used to change the website category

Correct Answer: B

QUESTION 7

Which of the following statements is true regarding client integrity checking in SSL VPN? Response:

- A. It detects the Windows client security applications running in the SSL VPN client's PCs.
- B. It validates the SSL VPN user credentials on the remote authentication server.
- C. It verifies which SSL VPN portal must be presented to each SSL VPN user.
- D. It verifies that the latest SSL VPN client is installed in the client's PC.

Correct Answer: A

QUESTION 8

Examine the following log message attributes and select two correct statements from the list below.

(Choose two.)

Response:

- A. The category action was set to warning.
- B. The website was allowed on the first attempt.
- C. The user was prompted to decide whether to proceed or go back.

D. The user failed authentication.

Correct Answer: BC

QUESTION 9

An administrator needs to inspect all web traffic (including Internet web traffic) coming from users connecting to SSL VPN. How can this be achieved?

Response:

- A. Disabling split tunneling
- B. Configuring web bookmarks
- C. Assigning public IP addresses to SSL VPN clients
- D. Using web-only mode

Correct Answer: A

QUESTION 10

LDAP and RADIUS are both remote authentication servers that FortiGate can tie into for authentication. What is a key difference between these servers?

Response: A. Only LDAP can have a secure connection with FortiGate using a server certificate.

- B. Only LDAP can be configured to authenticate groups as defined on the LDAP server.
- C. Only LDAP provides authentication, authorization, and accounting (AAA) services.
- D. Only RADIUS requires a distinguished name (i h.) to locate user records.

Correct Answer: A

QUESTION 11

You have enabled a web filter security profile in a firewall policy to log all blocked websites. What options do you have to either actively or passively monitor these logs? (Choose two.)

Response: A. Alert Message console

- B. FortiView menu
- C. Alert email
- D. Monitor menu

Correct Answer: AC

QUESTION 12

Which of the following statements about the FortiGate application control database are true?

(Choose two.)

Response:

- A. The application control database uses TCP port 53 for downloads.
- B. The application control database uses a hierarchical structure to organize application signatures.
- C. The application control database is part of the IPS signatures database.
- D. The application control database updates are included in the free FortiGuard service.

Correct Answer: BD

QUESTION 13

Which of the following are differences between IPsec main mode and IPsec aggressive mode?

(Choose two.)

Response:

- A. Aggressive mode supports XAuth, while main mode does not.
- B. Six packets are usually exchanged during main mode, while only three packets are exchanged during aggressive mode.
- C. The first packet of aggressive mode contains the peer ID, while the first packet of main mode does not.
- D. Main mode cannot be used for dialup VPNs, while aggressive mode can.

Correct Answer: BC

QUESTION 14

Which of the following statements about web caching are true?

(Choose two.)

Response:

- A. Web caching slows down web browsing due to constant read-write cycles from FortiGate memory.
- B. When a client makes a web request, the proxy checks if the requested URL is already in memory.
- C. Only heavy content is cached, for example, videos, images, audio and so on.

D. Web caching is supported in both explicit and implicit proxy.

Correct Answer: BD

QUESTION 15

What FortiGate feature can be used to prevent a cross-site scripting (XSS) attack? Response:

- A. Web application firewall (WAF)
- B. DoS policies
- C. Rate based IPS signatures
- D. One-arm sniffer

Correct Answer: A

[NSE4_FGT-5.6 PDF Dumps](#) [NSE4_FGT-5.6 VCE Dumps](#)

[NSE4_FGT-5.6 Practice Test](#)